

® Bunk Beds Unlimited

***BUNK BEDS UNLIMITED***

# **XL Storage Drawers Plan**





## Introduction to Storage Drawers Plan

Thank you for purchasing the Bunk Beds Unlimited Storage Drawers Plan. These drawers are very basic structures and, like your bed, can be easily built with a few power tools and a few hand tools. We have built and sold many similar drawer sets through the years and have refined this plan so that it is simple to build, and of very good quality.

Much thought and effort has been put into this plan in order to make it as easy as possible to follow. Please take some time and get a feel for the plan and become familiar with all of the parts before beginning. The majority of the work you put into the bed will be in finishing and assembly. The drawers are especially useful in allowing quick and easy access to a large amount of items as well as some pretty large items. We sincerely hope that you have fun while you follow these simple directions. If you run into any problems you can e-mail us at: [info@BunkBedsUnlimited.com](mailto:info@BunkBedsUnlimited.com). Again, thank you for your purchase.

This Storage Drawers Plan is published by: Bunk Beds Unlimited,  
3807 Rolf St. Tallahassee FL 32303

© Copyright 2002 Bunk Beds Unlimited Tallahassee Florida all rights reserved. By Federal law, no part of this publication may be copied or reproduced in any form or by any means including but not limited to electronic, mechanical, photocopying, recording or otherwise stored in a retrieval system, or transmitted in any form or by any means including but not limited to electronic, mechanical, photocopying, recording or otherwise without prior written permission from the publisher.

# Storage Drawers Plan

The storage drawers will greatly improve the storage area under your bunk bed. The design of the drawers is not too complex. They are basic box structures with the addition of casters to allow them to be moved in and out easily. You will need 2x10" material in the quantities shown on [Page 3](#). The bottoms are made from plywood or some other sheet material. You should have enough scrap left from your bunk boards to fit the bottom panels in one of the two drawers. A half-sheet of plywood is sufficient for the other. As with the bunk bed, the final appearance depends on how much work you are willing to put into the details of sanding and finishing. The addition of handles will give the drawers a much more finished look.

Begin by cutting the 2x10" and 2x2" parts to length as shown in the table on [page 4](#). **In order to obtain the best results, the drawer bottom panels should be cut to fit after the sides and fronts are assembled.** Remember to put the nicest looking face pieces on the front

[Page 5](#) shows where to drill for your lag bolts.

If you purchased 5/16" lag bolt (screws) and washers from a hardware store You will need to drill 5/16" holes completely through the front and back panels. Likewise, drill 1/4" pilot holes in the ends of the sides 1 1/4" deep.

If you purchase a hardware kit from Bunk Beds Unlimited, it will include decorative furniture lag bolts that need 9/32" holes through the front and back panels. Likewise, drill 3/16" pilot holes in the ends of the sides 1 1/4" deep.

Next, do all sanding and finishing.

Begin assembly by attaching the cleats to the drawer sides. Use 4 -2 1/2" wood screws in each cleat. Now attach the front and back panels to the sides using lag bolts. The drawers are ready for bottom panels. Each drawer gets two panels (See [Page 6](#).) These should fit pretty snugly and are best attached to the side cleat using 4 -1 1/2" wood screws per panel. You can now drill holes in the cleats for your casters. Drill the appropriate size holes 2 inches from the ends of the cleats and insert the caster stems into them. If you purchased the hardware kit for your bed and drawers from Bunk Beds Unlimited, you will need to drill 7/16" holes for the caster stems to fit in. See [page 6](#). The handles provided in your hardware kit should be attached by drilling 3/16" holes at the locations shown on [page 5](#).

Attach the drawer guides part #9 to the bottom ladder rung using 3-2 1/2" wood screws. These will keep the drawers from easily getting stuck.

## Shopping List

<b>Hardware Requirements for Drawers</b>		
Quantity	Size	Name
16	5/16" x 4"	Lag bolts and Washers
16	2 1/2" #8	Phillips Wood Screws
16	1 1/2" #8	Phillips Wood Screws
8	2"	Furniture Casters

\* If you did not purchase the hardware package you may want to consider purchasing 4 handles to enhance the appearance.

**These lists describe the materials you will need to build the storage drawers.**

<b>Lumber Requirements for Drawers</b>		
Quantity	Size	Name
4	2 x 10 x 8'	Sides Front and Back Panels
2	2 x 2 x 8'	Cleats for Bottoms
4	3/4 x 19 1/2 x 37 1/2"	Bottom Panels <b><u>MEASURE FIRST!</u></b>

## Storage Drawers Plan

# Storage Drawers Section



## Lumber Required

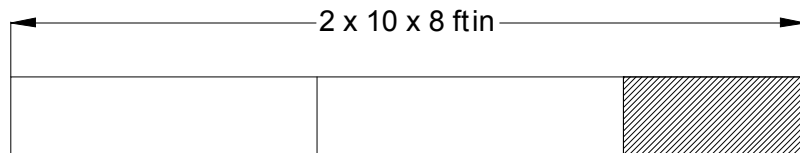

**2 Needed**

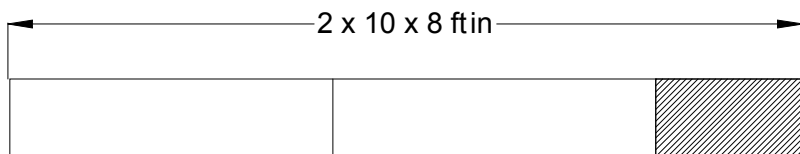

**2 Needed**

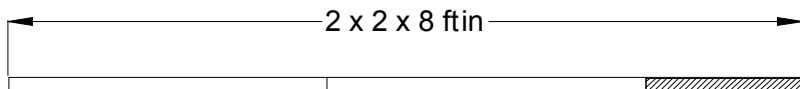

**2 Needed**

Hardware Requirements		
Quantity	Size	Name
16	5/16" x 4"	Lag bolts and Washers
16	2" #8	Phillips Wood Screws

## Storage Drawers Plan

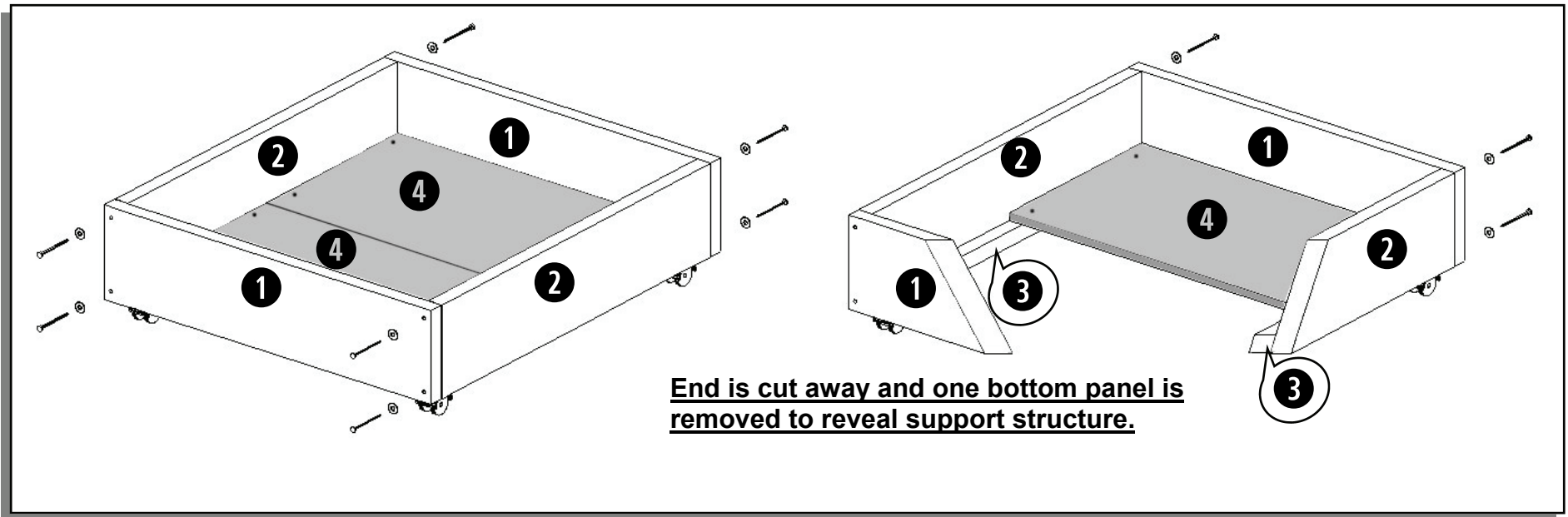

Key to Parts Continued			
Part Number	Qty	Dimensions	Description
1	4	2 x 10 x 40 1/2"	Front and Rear Panels
2	4	2 x 10 x 39"	Left and Right Side Panels
3	4	2 x 2 x 38"	Bottom Support Cleat
4	4	3/4 x 19 1/2 x 37 1/2" * <i><b>APPROXIMATE! MUST be Measured Before Cutting!</b></i>	Drawer Bottom Panels
5	8	2"	Stemmed Furniture Casters
6	8	3 3/4"	Wooden Handles

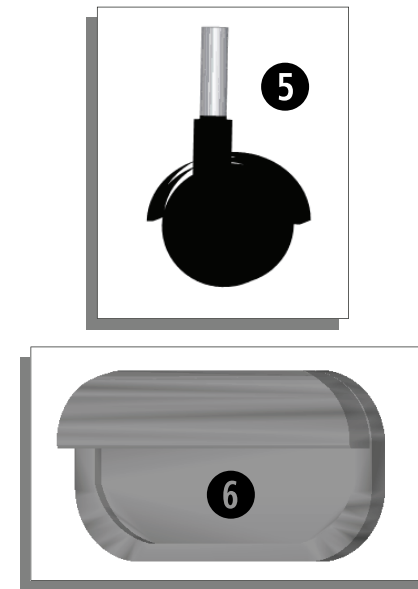

## Storage Drawers Plan

# Storage Drawer Drilling Guide

## Face Panel Handle Drilling Guide for Handles

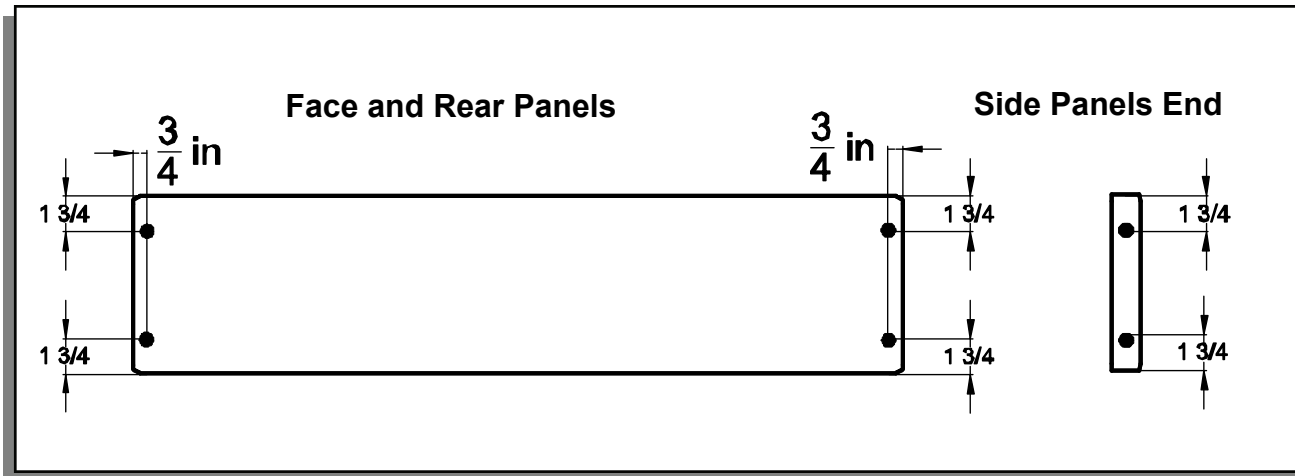
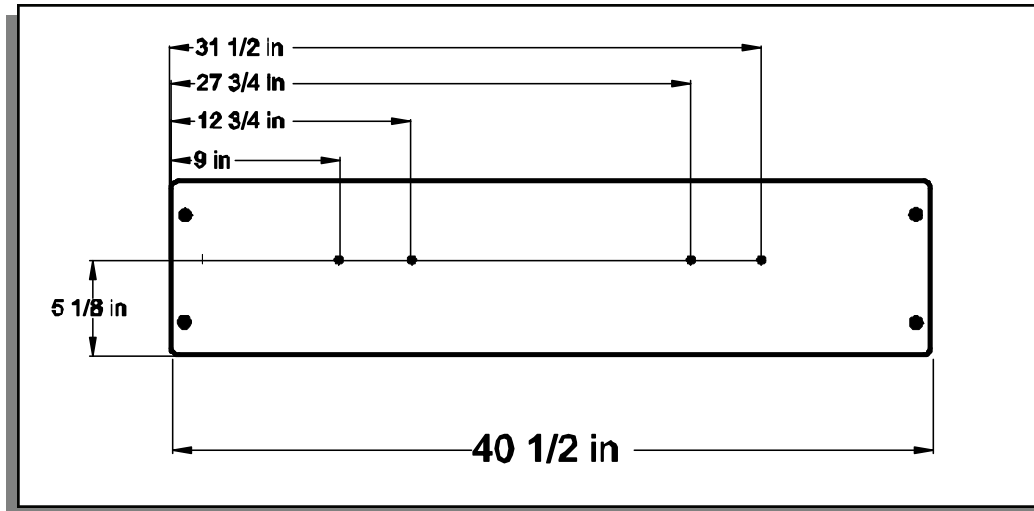

# Storage Drawers Plan

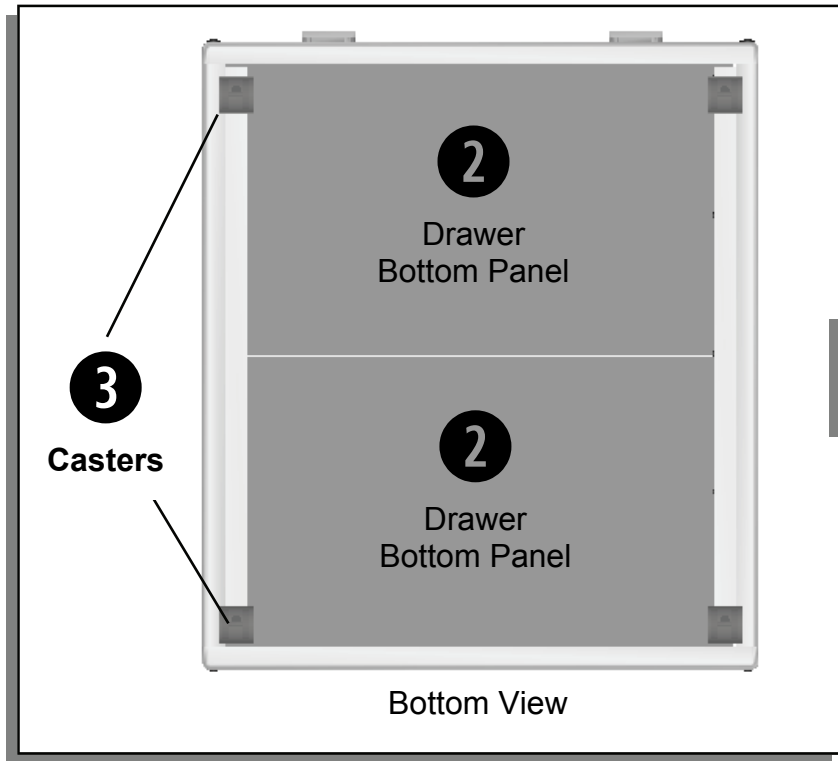

Holes for casters should be 1 ½ - 2" end of cleats.

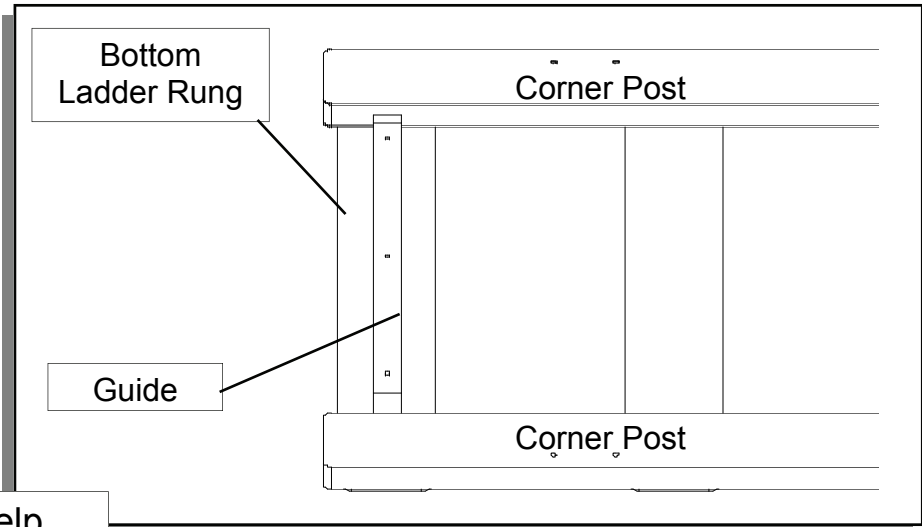

The 2x2 guide will help keep the drawers straight.

# Storage Drawers Plan